

+ Actuators

Specialist in Ball Valves



ACTUATORS DA

Basic Operating Details

- Port "A" Air to open (anti clockwise)
- Port "B" Air to close (clockwise)
- Air supply: 6 bar; maximum 7 bar
- Drive Medium = Air (Dry or lubricated); not corrosive Gas; light hydraulic oil
- Temperature= Buna nitrile o'seals -40° to 80°C or -40 to 176° F
- Standard indicator position

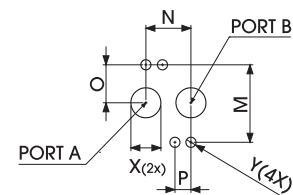

Selenoid mounting for all actuators

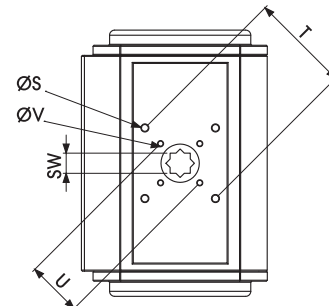
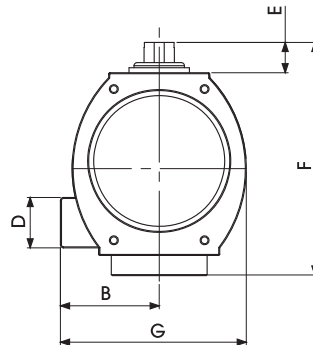
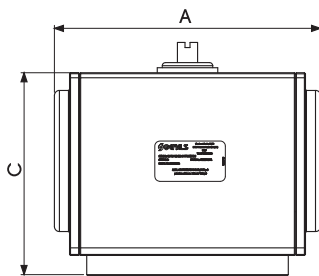

DA ACTUATORS (double acting)

TYPE	ISO5211	A	B	C	D	E	F	G	M	N	O	P	ØS	T	ØV	U	X	Y	SW	WEIGHT Kg	ITEM CODE
DA25	F03-F05	149,5	38	70	40	20	90	69,5	32	24	16	12	M6	50	M5	36	G1/8 x12	M5X8	9	1	FATDA0250401SH
DA100	F05-F07	206	59	118	43	20	138	113	32	24	16	12	M8	70	M6	50	G1/8 x12	M5X8	14	2,8	FATDA1000401SH
DA200	F05-F07	218	72	140,5	43	20	160,5	136,5	32	24	16	12	M8	70	M6	50	G1/4 x12	M5X8	17	7,0	FATDA2000401SH
DA375	F07-F10	266	78	166,5	43	30	196,5	156	32	24	16	12	M10	102	M8	70	G1/4 x12	M5X8	22	10,5	FATDA3750401SH
DA825	F10-F12	340	95,5	207,5	43	30	237,5	191	32	24	16	12	M12	125	M10	102	G1/4 x12	M5X8	27	22,4	FATDA8250401SH

VALVES WITH DA ACTUATORS

TYPE	BALL VALVES	DN
DA25	GE-GHP-GN-GR-SB	06-10-13
DA100	GE-GHP-GN-GR-SB	20-25
DA200	GB-GHP-GN-GR-SB	32-40
DA375	GB-GHP-GN-GR-SB	50-65
DA825	GR-SB	80-100-125

DA ACTUATORS TORQUE MOMENT

TYPE	AIR SUPPLY	N/m
DA25	6 BAR	23,7
DA100	6 BAR	101,5
DA200	6 BAR	201,9
DA375	6 BAR	374
DA825	6 BAR	824



+ Actuators

Specialist in Ball Valves

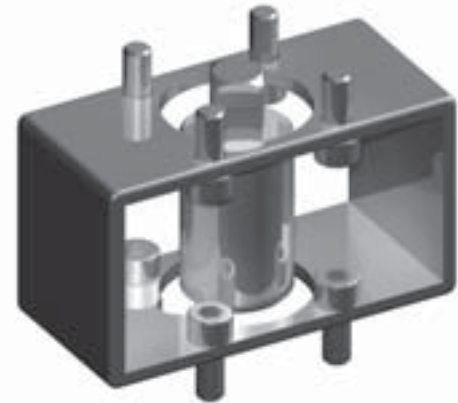
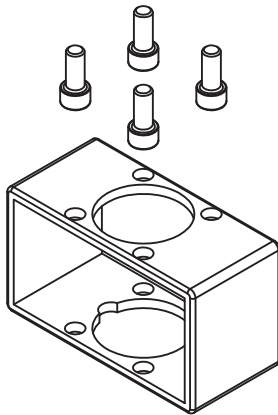

KITS WASHER
ONLY FOR GN-GB VALVES -KIT ACTUATOR
C0034406H FOR DN6-DN10-DN13-DN20-DN25-DN32
C0034306H FOR DN40-DN50

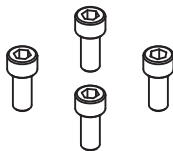
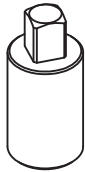

DA ACTUATORS KITS

TYPE	BALL VALVES	DN	MATERIAL	ISO5211	WHEIGHT Kg	ITEM CODE
AK65	SB	65-80	CARBON STEEL	F05 F07-F05	0,74	KOC00AK651X
AK32	SB	32-40	CARBON STEEL	F05 F07-F05	0,60	KOC00AK321X
AK40	GB-GHP-GN-GR-SB	32-40	CARBON STEEL	F05 F07-F05	0,67	KOC00AK401X
AK20	GE-GB-GHP-GN-GR-SB	20-25	CARBON STEEL	F05 F07-F05	0,52	KOC00AK201X
AK6	GE-GHP-GN-GR-SB	06-10-13	CARBON STEEL	F03-F03	0,25	KOC00AK61X
AK13	GE-GHP-GN-GR	13	CARBON STEEL	F03-F05	0,31	KOC00AK131X
AK100	GR-SB	100-125	CARBON STEEL	F10 F12-F12	2,05	KOC00AK1001X
AK50	GB-GHP-GN-GR-SB	50	CARBON STEEL	F05 F07-F05	0,71	KOC00AK501X
AK6S	GN	06-10-13	CARBON STEEL	F03 F05-F03 F05	0,30	KOC00AK6S1X

+ Actuators



ACTUATORS SR

Basic Operating Details

- Port "A" Air to open (anti clockwise compressing spring)
- Port "B" Spring to close (clockwise)
- Air supply: 6 bar; maximum 7 bar
- Drive Medium = Air (Dry or lubricated); not corrosive Gas; light hydraulic oil
- Temperature = Buna nitrile o'seals -40° to 80°C or -40° to 176° F
- Standard indicator position

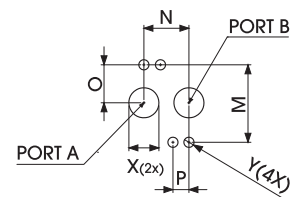

Solenoid mounting for all actuators

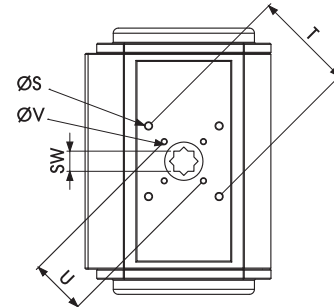
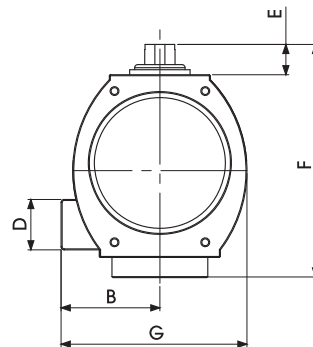
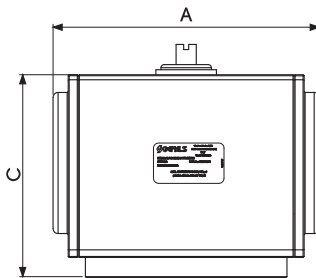

SR ACTUATORS (spring return)

TYPE	ISO5211	A	B	C	D	E	F	G	M	N	O	P	ØS	T	ØV	U	X	Y	SW	WEIGHT Kg	ITEM CODE
SR25	F03-F05	149,5	38	70	40	20	90	69,5	32	24	16	12	M6	50	M5	36	G1/8 x12	M5x8	9	1	FATSR0250401SH
SR50	F05-F07	185	49	87	40	20	107	90,5	32	24	16	12	M8	70	M6	50	G1/8x12	M5x8	11	1,9	FATSR0500401SH
SR100	F05-F07	206	59	118	43	20	138	113	32	24	16	12	M8	70	M6	50	G1/8 x12	M5x8	14	2,8	FATSR1000401SH
SR200	F05-F07	218	72	140,5	43	20	160,5	136,5	32	24	16	12	M8	70	M6	50	G1/4 x12	M5x8	17	7	FATSR2000401SH
SR375	F07-F10	266	78	166,5	43	30	196,5	156	32	24	16	12	M10	102	M8	70	G1/4 x12	M5x8	22	10,5	FATSR3750401SH
SR600	F10-F12	312	95,5	207,5	43	30	237,5	191	32	24	16	12	M12	125	M10	102	G1/4x12	M5x8	27	20,6	FATSR6000401SH
SR825	F10-F12	340	95,5	207,5	43	30	237,5	191	32	24	16	12	M12	125	M10	102	G1/4 x12	M5x8	27	22,4	FATSR8250401SH

VALVES WITH SR ACTUATORS

TYPE	BALL VALVES	DN
SR25	GE-GHP-GN-GR-SB	06-10
SR50	GE-GHP-GN-GR-SB	13
SR50	GN	06-10-13
SR100	GE-GB-GHP-GN-GR-SB	20-25
SR200	GB-GHP-GN-GR-SB	32-40
SR375	GB-GHP-GN-GR-SB	50-65
SR600	GB-GHP-GN-GR-SB	80-100 (LOW PRESSURE)
SR825	GR-SB	80-100-125

SR ACTUATORS TORQUE MOMENT

TYPE	AIR SUPPLY	AIR-START N/m	AIR-END N/m	SPRING-START N/m	SPRING-END N/m	N°SPRING
SR25	6 BAR	16,3	9,3	14,41	7,37	11
SR50	6 BAR	32,7	18,1	32,64	18	12
SR100	6 BAR	61,4	40,1	61,3	40	12
SR200	6 BAR	130,33	71,73	130,2	71,6	4X4
SR375	6 BAR	241,54	132,98	241,2	132,64	4X4
SR600	6 BAR	385,20	212,1	384,6	211,5	4X4
SR825	6 BAR	533	294	531	292	4X4

+ Actuators

2014 - Edition 2

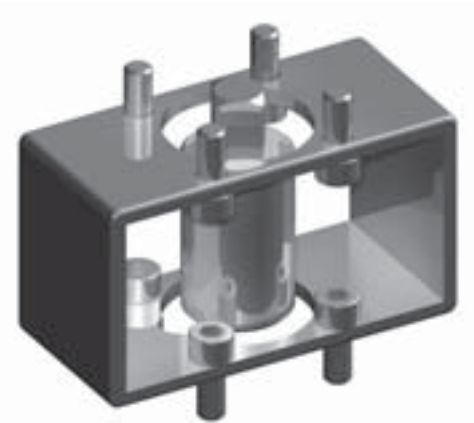
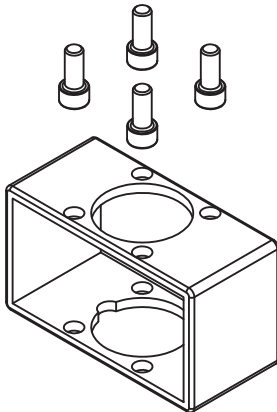

KITS WASHER
ONLY FOR GN-GB VALVES -KIT ACTUATOR
C0034406H FOR DN6-DN10-DN13-DN20-DN25-DN32
C0034306H FOR DN40-DN50

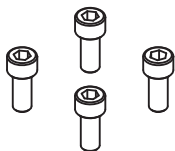
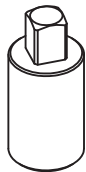

SR ACTUATORS KITS

TYPE	BALL VALVES	DN	MATERIAL	ISO5211	WHEIGHT Kg	ITEM CODE
AK65	SB	65-80	CARBON STEEL	F05 F07-F05	0,74	KOC00AK651X
AK32	SB	32-40	CARBON STEEL	F05 F07-F05	0,60	KOC00AK321X
AK40	GB-GHP-GN-GR-SB	32-40	CARBON STEEL	F05 F07-F05	0,67	KOC00AK401X
AK20	GE-GB-GHP-GN-GR-SB	20-25	CARBON STEEL	F05 F07-F05	0,52	KOC00AK201X
AK6	GE-GHP-GN-GR-SB	06-10-13	CARBON STEEL	F03-F03	0,25	KOC00AK61X
AK13	GE-GHP-GN-GR	13	CARBON STEEL	F03-F05	0,31	KOC00AK131X
AK100	GR-SB	100-125	CARBON STEEL	F10 F12-F12	2,05	KOC00AK1001X
AK50	GB-GHP-GN-GR-SB	50	CARBON STEEL	F05 F07-F05	0,71	KOC00AK501X
AK6S	GN	06-10-13	CARBON STEEL	F03 F05-F03 F05	0,30	KOC00AK6S1X